

/// Frozen Drink Machine

6450-C

115V - Gravity Feed

- ☆ Single Flavor // Countertop
- ☆ Up to 110, 10oz drinks per hour
- ☆ 4 Qt Cylinder - 12.6 Qt Hopper
- ★ Perfect solution for alcoholic and non-alcoholic frozen beverages in bars and restaurants



Fast Freeze Down

Patented high efficiency heat exchanger allows fast freeze down with low energy consumption

Reduced Parts - Easy Cleaning

Reduced parts and single piece beater/shaft design improve cleaning time and operational experience

Simple Control, Easy Operation

Simple and intuitive control system makes operation and viscosity adjustment easy, swift and more precise

Low Mix Indicator & Freeze Protection

Light turns "ON" at low mix to alert operator to add mix. Prevents Freeze Ups when mix is out

Safety Protections & Light Box Merchandising

High pressure switch prevents compressor overheating. Thermal overload protects motor and drive train. Illuminated flavor cards to attract more business

Self-closing Dispensing Valve

Automatically prevents product overflow after dispense



★ The Spaceman Difference

QUALITY

Affordable Quality

Designed by Aerospace Engineers

- ✓ Craft quality design, less investment
- ✓ Built to last
- ✓ Luxurious mouthfeel

VALUE

Microcrystal Technology

3X Patented Freezing Speed

- ✓ Superior fast freeze
- ✓ Quick recovery
- ✓ Lowest energy cost per serving

SERVICE

Restriction-Free Service

Service on Your Terms

- ⊘ No binding contracts
- ⊘ No locked-in maintenance fees
- ⊘ No monthly equipment costs

/// Frozen Drink Machine

6450-C

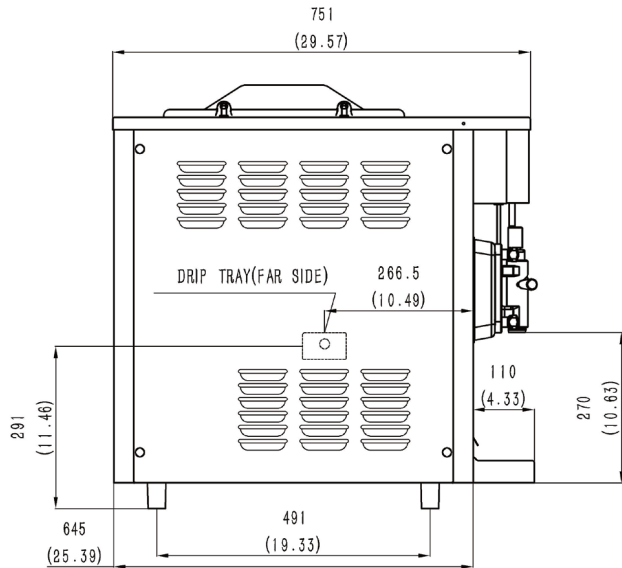
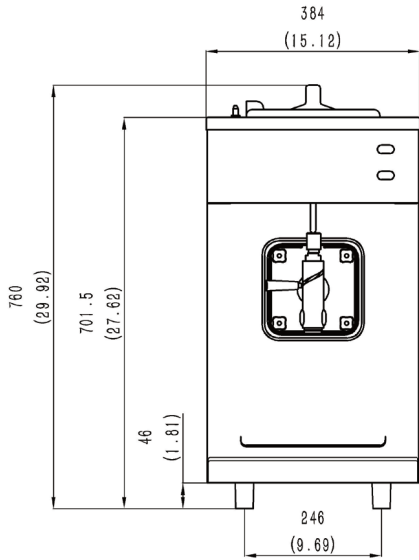

Specifications

Flavors	1
Freezing Cylinders	1 x 3.8L / 4.0 Qt
Mix Hoppers	1 x 12L / 12.6 Qt
Output Capacity (10oz servings)	110 servings/hr
Max Serving Size	16oz
Clearance Requirements	152mm/6"

Weight

Kg/lb

Net	99 / 220
Shipping	109 / 242
Volume	0.29 CBM / 10.13 CBF

Dimensions

Net (mm/in)

Shipping (mm/in)

Width	384 / 15.1	420 / 16.5
Depth	645 / 25.4	770 / 30.3
Height	760 / 29.9	890 / 35.0

Electrical

Plug(NEMA)

MFS

MCA

Power(kW)

110-115/60/1	5-20	20	15	1.3
--------------	------	----	----	-----

Features

Control System	One, Mechanical
Auto Closing Dispensing Valve	✓
Low Mix Indicator Light	✓
High Pressure Protection	✓
Thermal Overload Protection	✓

*Above specifications are subject to change without notice