

## /// Soft Serve Machine

# 6378-C

220V - Gravity Feed

- ☆ Two Flavor // Standalone (Floor)
- ☆ Digital Control
- ☆ Up to 700, 4oz servings per hour
- ☆ (2) 3.4 Qt Cylinder - (2) 20 Qt Hopper
- ★ Ideal for high capacity outlets to serve ice cream, frozen yogurt, gelato or sorbet. Fully loaded with all standard options. Small footprint saves counter space.



### Gravity Feed

The Spaceman gravity-fed machines produce consistent product quality with a solution that is easy to operate and easier to clean with less moving parts.

#### Fast Freeze Down

Patented high efficiency heat exchanger allows fast freeze down with low energy consumption

#### Auto Programming

Allows automatic switching of operation modes based on preset schedules

#### Standby

Maintains product temperature in both mix hopper and freezing cylinder below 4.4°C (40°F) overnight

#### Hopper Agitator

Maintain product consistency and prevent product separation

#### Defrost for Cleaning

Increases efficiency during cleaning by heating frozen product in cylinder

#### Quick Freeze

Turn on freeze immediately to freeze down to serving viscosity when quick service is required after long idle period

#### Self-closing Valve with Speed Control

Automatically prevents product overflow after dispense; Provides flexibility in dispense rate control

#### Reduced Parts

Reduced parts improve cleaning time and operational experience.

## ★ The Spaceman Difference

### QUALITY

#### Affordable Quality

##### Designed by Aerospace Engineers

- ✓ Craft quality design, less investment
- ✓ Built to last
- ✓ Luxurious mouthfeel

### VALUE

#### Microcrystal Technology

##### 3X Patented Freezing Speed

- ✓ Superior fast freeze
- ✓ Quick recovery
- ✓ Lowest energy cost per serving

### SERVICE

#### Restriction-Free Service

##### Service on Your Terms

- ⊘ No binding contracts
- ⊘ No locked-in maintenance fees
- ⊘ No monthly equipment costs

/// Soft Serve Machine

# 6378-C

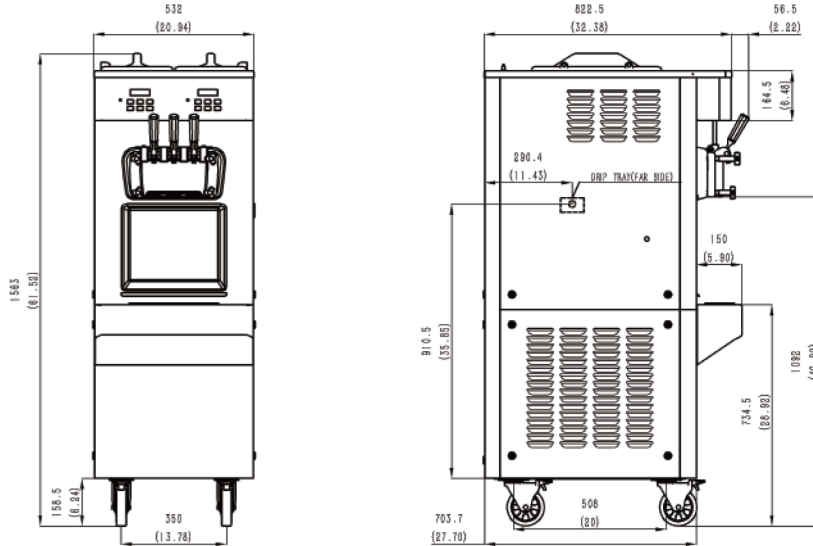

## Specifications

Flavors	2 + Twist
Freezing Cylinders	2 x 3.2L / 3.4 Qt
Mix Hoppers	2 x 15L / 20 Qt
Output Capacity (4oz serving)	700 serves/hr
Max Serving Size	16oz
Clearance Requirements	152mm/6"

Weight	Kg/lb
Net	253 / 562
Shipping	273 / 607
Volume	1.09 CBM / 3 8.62 CBF

Dimensions	Net (mm/in)	Shipping (mm/in)
Width	532 / 20.9	710 / 28.0
Depth	704 / 27.7	890 / 35.0
Height	1563 / 61.5	1730 / 68.1

Electrical	Plug(NEMA)	MFS	MCA	Power(kW)
380-415/50/3	L6-30	15	11	4.4
208-230/60/3	L15-30	30	23	4.8
208-230/60/1	L6-30	30	24	4.9

## Features

Control System	Two, Digital
Refrigerated Hopper	✓
Hopper Agitator	✓
Temperature Display	✓
Standby Mode	✓
Auto Closing Dispensing Valve	✓
Dispensing Speed Control	✓
Low Mix Indicator Light & Alarm	✓
Low Temperature Protection	✓
Motor Overload Protection	✓
High Pressure Protection	✓
Defrost & Quick Freeze	✓
Soft Start	✓

## Available Options

Water Cooled	✓
Top Air Discharge Chute	✓

\*Above specifications are subject to change without notice