

/// Soft Serve Machine

6236-C

220V - Gravity Feed

- ☆ Single Flavor // Countertop
- ☆ Digital Control
- ☆ Up to 350, 4oz servings per hour
- ☆ 3.4 Qt Cylinder - 20 Qt Hopper
- ★ Ideal for high capacity outlets to serve ice cream, frozen yogurt, gelato or sorbet. Fully loaded with all standard options. Small footprint saves counter space.



Gravity Feed

The Spaceman gravity-fed machines produce consistent product quality with a solution that is easy to operate and easier to clean with less moving parts.

Fast Freeze Down

Patented high efficiency heat exchanger allows fast freeze down with low energy consumption

Auto Programming

Allows automatic switching of operation modes based on preset schedules

Standby

Maintains product temperature in both mix hopper and freezing cylinder below 4.4°C (40°F) overnight

Hopper Agitator

Maintain product consistency and prevent product separation

Defrost for Cleaning

Increases efficiency during cleaning by heating frozen product in cylinder

Quick Freeze

Turn on freeze immediately to freeze down to serving viscosity when quick service is required after long idle period

Self-closing Valve with Speed Control

Automatically prevents product overflow after dispense; Provides flexibility in dispense rate control

Reduced Parts

Reduced parts improve cleaning time and operational experience.

★ The Spaceman Difference

QUALITY

Affordable Quality

Designed by Aerospace Engineers

- ✓ Craft quality design, less investment
- ✓ Built to last
- ✓ Luxurious mouthfeel

VALUE

Microcrystal Technology

3X Patented Freezing Speed

- ✓ Superior fast freeze
- ✓ Quick recovery
- ✓ Lowest energy cost per serving

SERVICE

Restriction-Free Service

Service on Your Terms

- ⊘ No binding contracts
- ⊘ No locked-in maintenance fees
- ⊘ No monthly equipment costs

/// Soft Serve Machine

6236-C

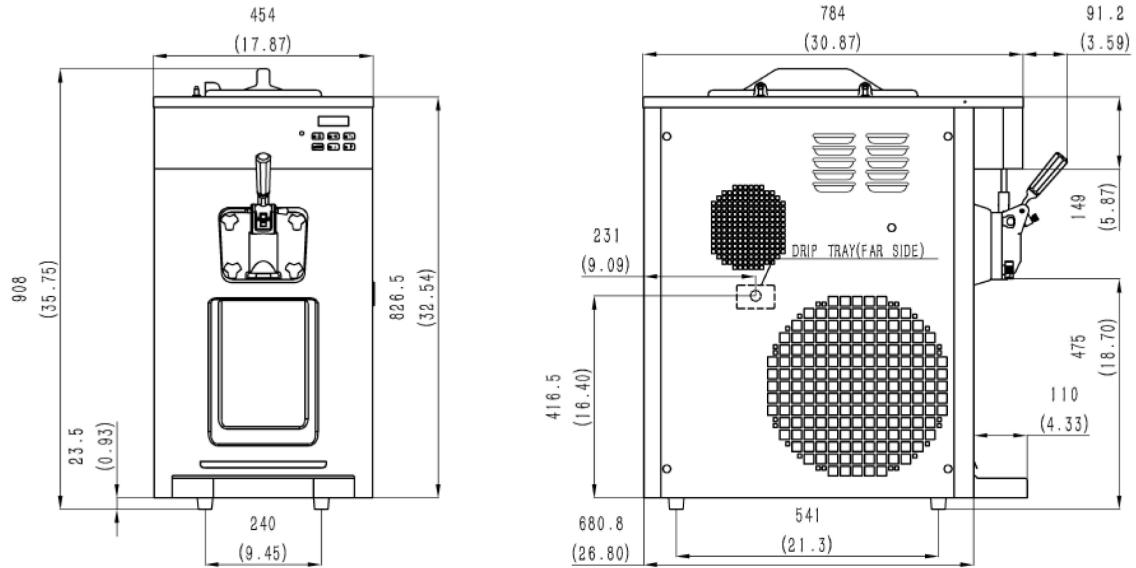

Specifications

Flavors	1
Freezing Cylinders	1 x 3.2L / 3.4 Qt
Mix Hoppers	1 x 12L / 20 Qt
Output Capacity (4oz servings)	350 serves/hr
Max Serving Size	16oz
Clearance Requirements	152mm/6"

Weight	Kg/lb (Gravity)
Net	139 / 309
Shipping	152/ 338
Volume	0.47 CBM / 1 6.62 CBF

Dimensions	Net (mm/in)	Shipping (mm/in)
Width	454 / 17.9	500 / 19.7
Depth	681 / 26.8	870 / 34.3
Height	908 / 35.8	1080 / 42.5

Electrical	Plug(NEMA)	MFS	MCA	Power(kW)
220-240/50/1	L6-20	20	13	2.4
208-230/60/1	L6-20	20	15	2.7

Features

Control System	Single, Digital
Refrigerated Hopper	✓
Hopper Agitator	✓
Temperature Display	✓
Standby Mode	✓
Auto Closing Dispensing Valve	✓
Dispensing Speed Control	✓
Low Mix Indicator Light & Alarm	✓
Low Temperature Protection	✓
Motor Overload Protection	✓
High Pressure Protection	✓
Defrost & Quick Freeze	✓
Soft Start	✓

Available Options

Water Cooled	✓
Top Air Discharge Chute	✓
Cart (Trolley)	✓

*Above specifications are subject to change without notice