

/// Soft Serve Machine

6210-C

115V - Gravity Feed

- ☆ Single Flavor // Countertop
- ☆ Digital Control
- ☆ Up to 120, 4oz servings per hour
- ☆ 1.3 Qt Cylinder - 8.5 Qt Hopper
- ★ Ideal for any business with limited counter space to add ice cream, frozen yogurt, gelato or sorbet. Flexible with digital control and display. Great fit for restaurants, bars, kitchens, convenience stores and delis.



Gravity Feed

The Spaceman gravity-fed machines produce consistent product quality with a solution that is easy to operate and easier to clean with less moving parts.

Fast Freeze Down

Patented high efficiency heat exchanger allows fast freeze down with low energy consumption

Auto Programming

Allows automatic switching of operation modes based on preset schedules

Standby

Maintains product temperature in both mix hopper and freezing cylinder below 4.4°C (40°F) overnight

Reduced Parts

Reduced parts improve cleaning time and operational experience.

Defrost for Cleaning

Increases efficiency during cleaning by heating frozen product in cylinder

Quick Freeze

Turn on freeze immediately to freeze down to serving viscosity when quick service is required after long idle period

Self-closing Valve with Speed Control

Automatically prevents product overflow after dispense; Provides flexibility in dispense rate control

★ The Spaceman Difference

QUALITY

Affordable Quality

Designed by Aerospace Engineers

- ✓ Craft quality design, less investment
- ✓ Built to last
- ✓ Luxurious mouthfeel

VALUE

Microcrystal Technology

3X Patented Freezing Speed

- ✓ Superior fast freeze
- ✓ Quick recovery
- ✓ Lowest energy cost per serving

SERVICE

Restriction-Free Service

Service on Your Terms

- ⊘ No binding contracts
- ⊘ No locked-in maintenance fees
- ⊘ No monthly equipment costs

/// Soft Serve Machine

6210-C

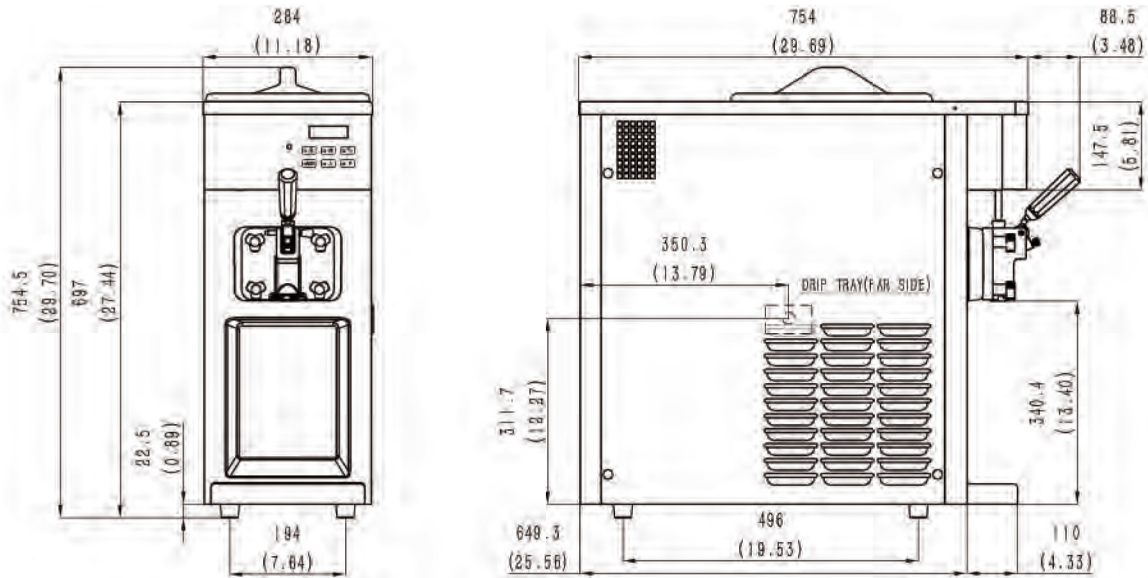

Specifications

Flavors	1
Freezing Cylinders	1 x 1.2L / 1.3 Qt
Mix Hoppers	1 x 8L / 8.5 Qt
Output Capacity (4oz servings)	120 serves/hr
Max Serving Size	8oz
Clearance Requirements	150mm/6"

Weight	Kg/lb (Gravity)
Net	90 / 198
Shipping	102 / 225
Volume	0.27 CBM / 9.53 CBF

Dimensions	Net (mm/in)	Shipping (mm/in)
Width	284 / 11.2	380 / 15.0
Depth	649 / 25.6	800 / 31.5
Height	755 / 29.7	900 / 35.4

Electrical	Plug(NEMA)	MFS	MCA	Power(kW)
110-115/60/1	5-20	20	16	1.6

Features

Control System	Single, Digital
Refrigerated Hopper	✓
Temperature Display	✓
Standby Mode	✓
Auto Closing Dispensing Valve	✓
Dispensing Speed Control	✓
Low Mix Indicator Light & Alarm	✓
Low Temperature Protection	✓
Motor Overload Protection	✓
High Pressure Protection	✓
Defrost & Quick Freeze	✓

Available Options

Cart (Trolley)	✓
----------------	---

*Above specifications are subject to change without notice